

### Application

- Main Steam System
- Condensate System
- HP Heater Drain System
- LP Heater Drain System
- Open-type Circulating Cooling Water System
- Auxiliary Steam System
- Heater Drain System
- Feed Water System
- petroleum & chemical system

- Variety of Trim Materials Optional
- Modular Design, Quick Maintenance
- The standard cage comes in three different flow characteristics
  - Quick Opening
  - Linear
  - Equal Percentage

Energy Fluid Technology Solution



**Delan** 德兰调节阀  
DELAN MA600 SERIES

## Content

Valve Characteristic .....	01
Anatomical Drawing .....	02
Typical Application .....	03
Sealing Valve Parts .....	04
Packing System .....	04
Outline Dimensions .....	08
Coefficient .....	10
Pneumatic Actuator .....	19
Technical Specifications .....	20





### Valve characteristics

● **Valve Plug Stability**

Rugged cage guiding provides increased valve plug stability which reduces vibration and mechanical noise.

● **Larger Flow Capacity**

Streamlined flow passages, low resistance, provide excellent capacity and flow.

● **Balanced Valve Plug Construction**

Plug & cage composes of pressure-balanced structure, high-precision and control range-ability, also suitable for high differential pressure condition.

● **High-Temperature Capability with Class IV or Class V Shutoff.**

Use of multiple graphite piston rings permit Class IV shutoff up to 593°C

Use of C-seal trim permits Class V shut off up to 593°C

● **Actuator**

Pneumatic diaphragm & cylinder piston double action actuator, compact structure and larger output force

● **Operational Economy**

Increased wear resistance provided by standard hardened stainless steel trim means larger service life.

● **Maintenance Economy**

Modular design of trim, easy maintenance

### Anatomical Drawing

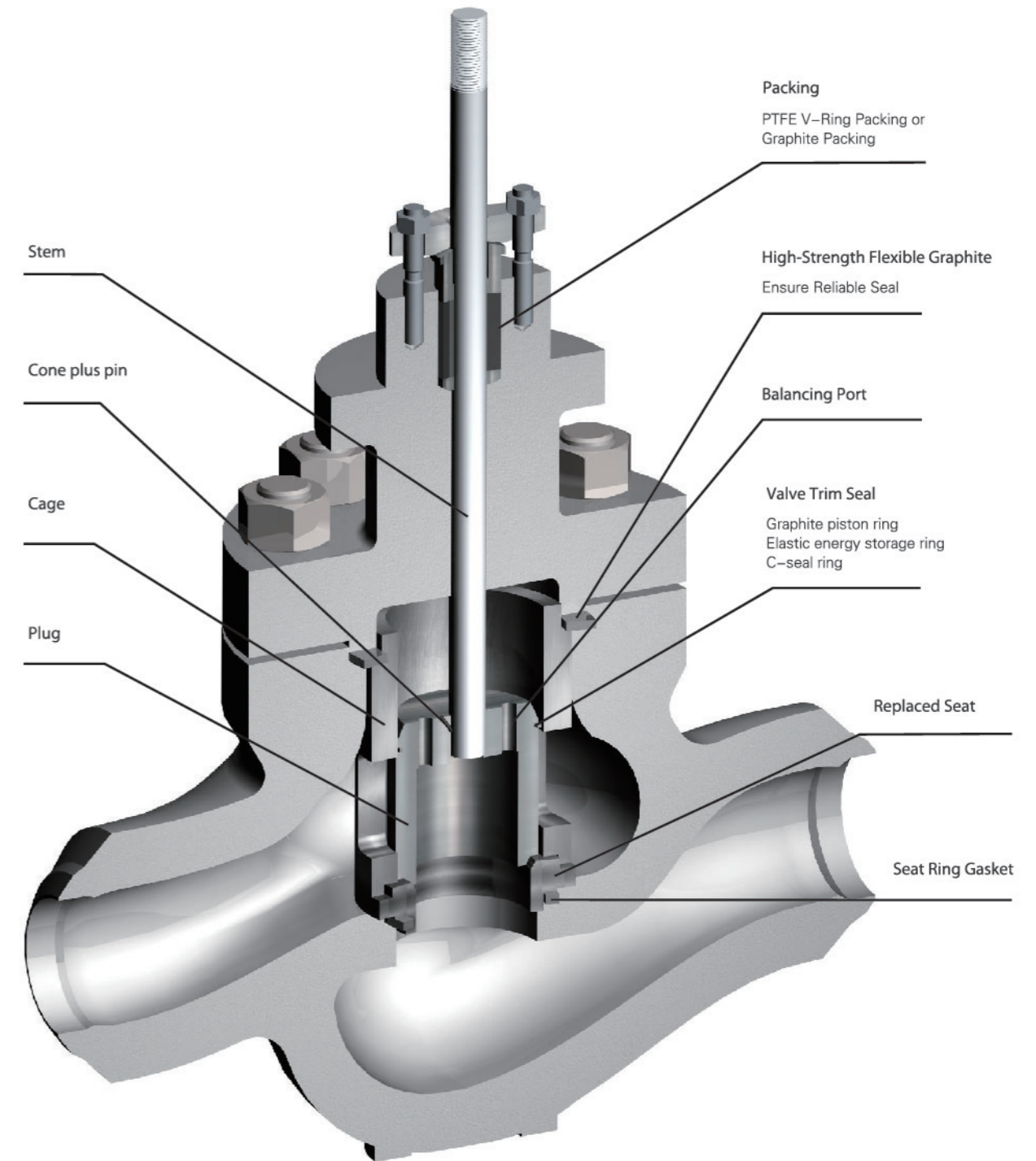

Figure 1: Globe Type Control Valve Sectional View

## Manufacturing range

**Table 1. Size Range**

Nominal Diameter													
NPS	In	1	1-1/2	2	2-1/2	3	4	6	8	10	12	14	16
DN	mm	25	40	50	65	80	100	150	200	250	300	350	400

**Table 2. Shutoff Classification & Temperature Capabilities**

Valve Size	Port Diameter		Cage Style	ANSI Leakage Class
	mm	NPS		
1"	26	1.024	E% Linear Fast Opening Anti-aircraft Noise reduction, Anti-cavitation	<b>II,III Class :</b> Standard single graphite piston rings permit class II, III shutoff up to 593 C  <b>IV Class :</b> with multiple graphite piston rings up to 593 C with elastic energy storage ring up to 232 C  <b>V Class :</b> with c-seal metal plug seal up to 593 C with elastic energy storage ring up to 232 C
1-1/2"	26	1.024		
2"	58	2.283		
2-1/2"	73	2.875		
3"	88	3.465		
4"	58	2.283		
	113	4.449		
6"	113	4.449		
	178	7.008		
8"	178	7.008		
	198	7.795		
10"	198	7.795		
	248	9.764		
12"	248	9.764		
	278	10.945		
14"	278	10.945		
	348	13.7		
16"	348	13.7		
	374	14.724		

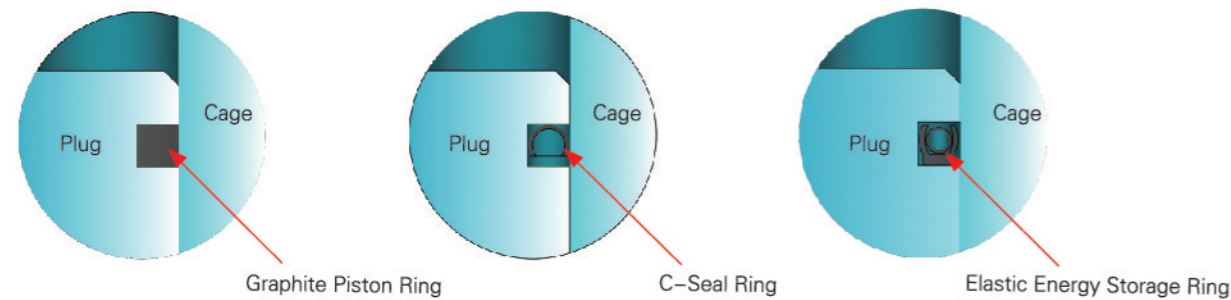

Figure 2: Valve Trim Sealing System

**Table 3. Pressure Rating Range**

Pressure Rating Range			
ANSI CLASS	150lb	300lb	600lb
GB/T9112-9124	1.6Mpa、2.0Mpa	4.0Mpa、5.0Mpa	6.3Mpa、10Mpa、11Mpa

**Table 4. Available Constructions**

Valve Size Inch	Valve body material and end connection style			
	Carbon steel, alloy steel, or stainless steel valve body			
	RF/RTJ Flanged			Butt-welding
	CL150	CL300	CL600	
1、1-1/2、2、2-1/2 3、4、6、8、10、12、14、16	◇	◇	◇	◇

◇ Available Construction

End connection style abbreviations: RF–Raised Face, RTJ–Ring Type Joint

## Sealing valve parts

With C-seal trim, a balanced valve can achieve high-temperature, class V shutoff. Because the C-seal plug seal is formed from metal, a valve equipped in processes with a fluid temperature of up to 593 C

## Packing system

### Graphite Packing System

For a superior stem seal in applications that are not environment-sensitive

### PTFE Packing System

Adopted live-loaded and unique packing-ring arrangements for long-term provide long packing life and reliability (consistent sealing performance)

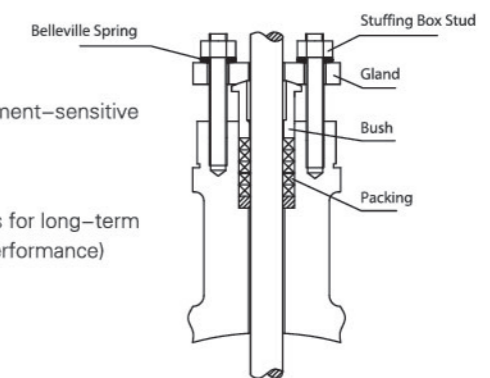

Figure 3: Packing System



**Table 5. Typical Combinations of Metal Trim Parts**

Body	Plug	Cage	Seat Ring	Seat
WCB	A182 F6a+stellite	A182 F6a	Elastic Energy Storage Ring	A182 F6a+stellite
WCB	A182 F6a+stellite	A182 F6a	C-Seal Ring	A182 F6a+stellite
WCB	A182 F6a+stellite	A182 F6a	GRAPHITE	A182 F6a+stellite
WC9	A182 F22+stellite	A182 F6a	Elastic Energy Storage Ring	A182 F22+stellite
WC9	A182 F22+stellite	A182 F6a	C-Seal Ring	A182 F22+stellite
WC9	A182 F22+stellite	A182 F6a	GRAPHITE	A182 F22+stellite
CF8M	A182 F316	A182 F316	Elastic Energy Storage Ring	A182 F316
CF8M	A182 F316	A182 F316	C-Seal Ring	A182 F316
CF8M	A182 F316	A182 F316	GRAPHITE	A182 F316
CF8	A182 F304	A182 F304	Elastic Energy Storage Ring	A182 F304
CF8	A182 F304	A182 F304	C-Seal Ring	A182 F304
CF8	A182 F304	A182 F304	GRAPHITE	A182 F304
CF3M	A182 F316L	A182 F316L	Elastic Energy Storage Ring	A182 F316L
CF3M	A182 F316L	A182 F316L	C-Seal Ring	A182 F316L
CF3M	A182 F316L	A182 F316L	GRAPHITE	A182 F316L
CF3	A182 F304L	A182 F304L	Elastic Energy Storage Ring	A182 F304L
CF3	A182 F304L	A182 F304L	C-Seal Ring	A182 F304L
CF3	A182 F304L	A182 F304L	GRAPHITE	A182 F304L

Note: This combination of parts applies to noise reduction, anti-cavitation & aircraft type valve

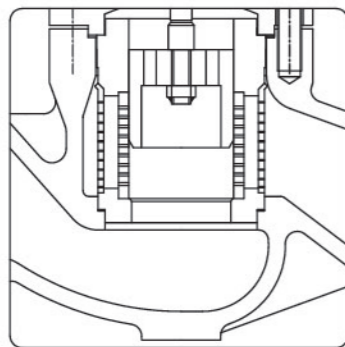

Figure 4: Noise reduction, Anti-cavitation type trim structure

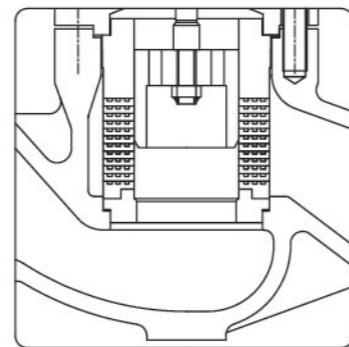

Figure 5: Anti-aircraft type trim structure

**Table 6. All other parts materials**

Parts	Material	
Seat Gasket	Flexible Graphite +316	
Stem	A182 F6a	
	A182 F316、A182 F316L	
	A182 F304、A182 F304L	
Bonnet	WCB	
	WC9	
	CF8M、CF8	
	CF3M、CF3	
Packing Washer	A276 410	
Packing	PTFE	
	Flexible Graphite +316	
Lock Nut	45	
Gland	1Cr13	
Gland Flange	1Cr13	
Body-Bonnet Bolt	Stud	A193 B16
		A193 B8
		35CrMoV
		A193 B7
	Nut	A194 2H
		35CrMo
		A194 4
		A194 8
Bonnet gasket	Flexible Graphite +316	
Gland-Bush Bolt	Stud	35CrMoA
	Nut	45

**Table 7. Bonnet Selection Guidelines**

Bonnet style	Packing Material	In-body process temperature limits
		°C
Plain	PTFE V-ring	-18—232
	PTFE/Composition	-18—233
	Graphite ribbon/filament	-18—593
Extension	PTFE V-ring	-101—427
	PTFE/Composition	
	Graphite ribbon/filament	-101—593

Table 8. Metal Trim Part Material for Compliance with NACE MR0175 (Sour Service) Specifications

Body	Plug	Cage	Seat Ring	Stem, Gland, Packing Washer, Stuffing Box Ring, Pin and Bush
CF8M	A182 F316	A182 F316 With electroless nicked coating (ENC)	A182 F316	A182 F316
WCB	A182 F6a+stellite	A182 F6a With electroless nicked coating (ENC)	A182 F6a	A182 F6a

Table 9. Bolting Materials and Temperature ranges for Bolting Compliance with NACE MR0175

Valve body material	Bolting materia	Temperature Capabilities		
		°C		Max.
		Min.		
<b>Non-exposed bolting (standard)</b>				
WCB	Stud	Steel SA-193-B7	-48	427
CF8M	Nut	Steel SA-193-2H		
<b>Exposed bolting (optional) No derating of valve required</b>				
WCB	Stud	Steel SA-193-B7M	-48	427
CF8M	Nut	Steel SA-193-2HM		

Outline dimensions

Table 10. Globe Control Valve Dimension

Valve Size		A						G (MAX) Globe Type
		Flange			BW	PN16-40	PN63-100	
mm	inches	150lb	300lb	600lb	150lb, 300lb, 600lb			
25	1"	184	197	210	210	160	230	60
40	1-1/2"	222	235	251	251	200	260	71
50	2"	254	267	286	286	230	300	78
65	2-1/2"	276	292	311	311	290	340	90
80	3"	298	318	337	337	310	380	97
100	4"	352	368	394	394	350	430	129
150	6"	451	473	508	508	480	550	162
200	8"	543	568	610	610	600	650	191
250	10"	673	708	752	752	730	775	250
300	12"	737	775	819	819	850	900	292
350	14"	889	927	972	972	980	1025	327
400	16"	1016	1057	1108	1108	1100	1150	370

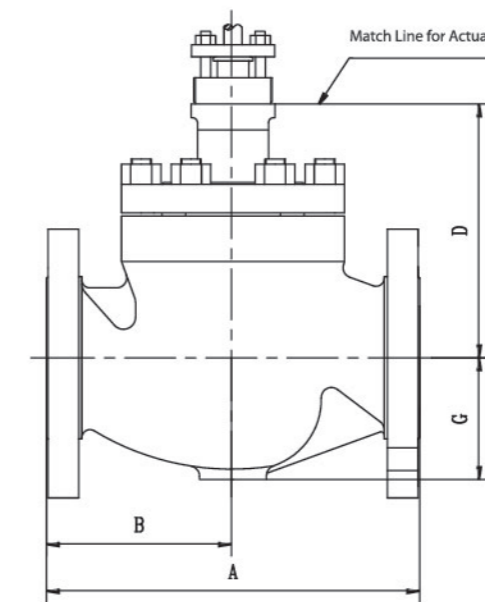

Figure 6: Globe Type Valve Dimension

Table 11. Globe Control Valve Dimension

Valve Size NPS	D (Plain Bonnet)					D (Ext. Bonnet)				
	Stem Diameter					Stem Diameter				
	mm					mm				
	12	14	16	20	26	12	14	16	20	26
1"	113	---	---	---	---	312	---	---	---	---
1-1/2"	---	---	164	---	---	---	---	346	---	---
2"	160	---	---	---	---	333	---	---	---	---
2-1/2"	---	216	---	---	---	---	406	---	---	---
3"	---	216	---	---	---	---	406	---	---	---
4"	---	230	---	---	---	---	462	---	---	---
6"	---	---	---	330	---	---	---	---	526	---
8"	---	---	---	475	---	---	---	---	621	---
10"	---	---	---	475	---	---	---	---	713	---
12"	---	---	---	505	---	---	---	---	745	---
14"	---	---	---	---	535	---	---	---	---	775
16"	---	---	---	---	663	---	---	---	---	816

Table 12. Angle Type Dimension

Valve Size NPS	DD						
	Plain Bonnet			Ext. Bonnet			
	Stem Diameter						
	mm						
	10	14	20	26	10	14	20
1	111	133	---	---	197	235	---
2	98	121	---	---	184	223	---
3	---	149	146	---	---	251	256
4	---	140	137	---	---	241	246
6	---	144	141	187	---	246	251

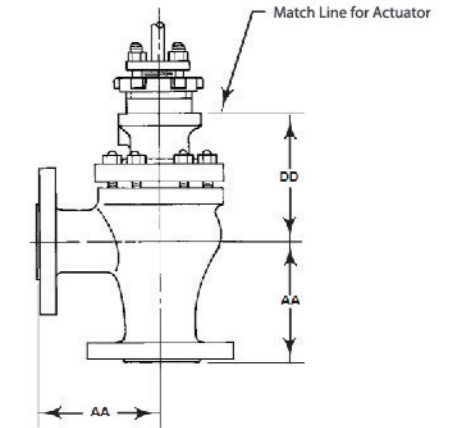

Figure 7: Angle Type Valve Dimension

Table 13. Angle Type Dimension

Valve Size NPS	AA					
	CL150		CL300		CL600	
	End Connection Style					
	RF	RTJ	RF	RTJ	BW, RF	RTJ
	mm					
1	92	98	98	105	105	105
2	127	133	133	141	143	144
3	149	156	159	167	168	170
4	176	183	184	197	197	198
6	225	232	237	244	254	256

End connection style abbreviations: BW — Butt welding FF — Flat Faced RF — Raised Face RTJ — Ring Type Joint



Coefficient

Table 14. Angle Type Control Valve—Quick Open Cage

Quick Opening Characteristic														
Valve Size	Port Diameter	Maximum Travel	Flow Coefficient	Valve Open-Percent of Total Valve										F <sub>L</sub>
NPS	mm	mm		10	20	30	40	50	60	70	80	90	100	
1	33	19	Cv	4.82	8.89	12.92	15.96	18.24	19.86	21.09	21.95	22.42	22.52	0.88
			Kv	4.13	7.62	11.07	13.68	15.63	17.01	18.07	18.80	19.21	19.29	---
2	48	19	Cv	7.66	14.92	23.66	32.59	40.95	48.45	54.25	58.33	61.37	63.84	0.89
			Kv	6.56	12.78	20.27	27.92	35.09	41.52	46.48	49.98	52.59	54.70	---
	33	19	Cv	5.72	9.88	14.63	19.86	25.75	32.02	36.58	39.62	41.99	43.32	0.71
			Kv	4.90	8.47	12.54	17.01	22.06	27.43	31.34	33.95	35.98	37.12	---
3	73	29	Cv	22.23	45.51	74.77	102.60	121.60	134.90	145.35	154.85	162.45	162.45	0.84
			Kv	19.05	38.99	64.07	87.92	104.20	115.60	124.55	132.69	139.20	139.20	---
	48	19	Cv	7.86	15.11	24.32	34.20	44.46	53.58	61.37	68.50	75.34	81.80	0.73
			Kv	6.73	12.94	20.84	29.31	38.10	45.91	52.59	58.69	64.55	70.09	---
4	88	38	Cv	22.71	45.79	76.29	112.10	143.45	169.10	185.25	198.55	211.85	211.85	0.74
			Kv	19.46	39.24	65.37	96.06	122.92	144.90	158.74	170.14	181.53	181.53	---
	60	29	Cv	12.92	25.65	41.71	59.38	76.57	91.20	103.55	114.00	120.65	126.35	0.75
			Kv	11.07	21.98	35.74	50.88	65.61	78.15	88.73	97.69	103.38	108.27	---
6	113	51	Cv	35.72	75.62	134.90	196.65	251.75	295.45	333.45	363.85	378.10	378.10	0.76
			Kv	30.61	64.80	115.60	168.51	215.72	253.17	285.73	311.78	323.99	323.99	---
	73	38	Cv	20.71	40.95	67.93	97.85	123.50	146.30	164.35	178.60	188.10	195.70	0.72
			Kv	17.75	35.09	58.20	83.85	105.83	125.36	140.83	153.04	161.18	167.69	---

Table 15. Angle Type Control Valve—Linear Cage

Flow Down Linear characteristic														
Valve Size	Port Diameter	Maximum Travel	Flow Coefficient	Valve Open-Percent of Total Valve										F <sub>L</sub>
NPS	mm	mm		10	20	30	40	50	60	70	80	90	100	
1	33	19	Cv	2.76	5.49	8.41	11.02	13.21	15.20	17.10	18.72	20.14	21.19	0.88
			Kv	2.36	4.71	7.20	9.44	11.32	13.02	14.65	16.04	17.26	18.15	---
2	48	19	Cv	3.50	6.63	10.74	15.11	19.76	25.08	31.07	37.24	43.42	49.88	0.84
			Kv	3.00	5.68	9.20	12.94	16.93	21.49	26.62	31.91	37.20	42.74	---
	33	19	Cv	2.86	5.18	8.50	11.88	15.11	18.15	22.14	26.98	31.54	35.72	0.72
			Kv	2.45	4.44	7.29	10.18	12.94	15.55	18.97	23.12	27.03	30.61	---
3	73	29	Cv	10.36	23.85	39.24	55.48	71.92	89.21	106.40	121.60	135.85	145.35	0.81
			Kv	8.87	20.43	33.62	47.54	61.62	76.44	91.17	104.20	116.41	124.55	---
	48	19	Cv	3.43	6.57	10.55	14.73	19.57	25.08	31.54	39.33	47.60	57.19	0.79
			Kv	2.94	5.63	9.04	12.62	16.77	21.49	27.03	33.70	40.78	49.01	---
4	88	38	Cv	13.30	32.11	53.49	76.19	98.80	120.65	140.60	160.55	175.75	190.95	0.77
			Kv	11.40	27.51	45.83	65.29	84.66	103.38	120.48	137.57	150.60	163.62	---
	60	29	Cv	6.67	14.92	24.42	35.06	46.17	57.86	69.26	80.37	92.34	102.60	0.75
			Kv	5.71	12.78	20.92	30.04	39.56	49.58	59.34	68.87	79.13	87.92	---
6	113	51	Cv	22.99	48.64	77.71	103.55	133.00	162.45	197.60	243.20	285.00	323.95	0.76
			Kv	19.70	41.68	66.59	88.73	113.97	139.20	169.32	208.40	244.22	277.59	---
	73	38	Cv	9.69	21.66	34.77	49.50	64.60	80.28	96.90	117.80	139.65	159.60	0.73
			Kv	8.30	18.56	29.79	42.41	55.36	68.79	83.03	100.94	119.67	136.76	---

Table 16. Angle Type Control Valve—Equal Percentage Cage

Flow Down Equal Percentage characteristic														
Valve Size	Port Diameter	Maximum Travel	Flow Coefficient	Valve Open-Percent of Total Valve										F <sub>L</sub>
NPS	mm	mm		10	20	30	40	50	60	70	80	90	100	
1	33	19	Cv	1.03	1.54	2.09	2.81	3.97	5.74	8.30	11.88	15.68	18.05	0.92
			Kv	0.88	1.32	1.79	2.41	3.40	4.92	7.11	10.18	13.43	15.47	---
2	48	19	Cv	1.59	2.47	3.63	5.16	7.40	11.59	17.96	26.03	35.91	44.84	0.84
			Kv	1.36	2.12	3.11	4.42	6.34	9.93	15.39	22.31	30.77	38.42	---
	33	19	Cv	1.05	1.47	1.95	2.73	3.87	5.65	8.40	12.73	18.62	25.46	0.72
			Kv	0.90	1.26	1.67	2.34	3.31	4.84	7.20	10.91	15.96	21.82	---
3	73	29	Cv	4.36	7.88	11.40	16.06	23.75	35.82	54.44	80.85	114.95	140.60	0.81
			Kv	3.74	6.75	9.77	13.76	20.35	30.69	46.65	69.28	98.50	120.48	---
	48	19	Cv	1.48	2.38	3.50	5.13	7.27	11.12	17.29	25.65	35.44	45.41	0.79
			Kv	1.27	2.04	3.00	4.40	6.23	9.52	14.82	21.98	30.36	38.91	---
4	88	38	Cv	2.38	4.85	7.63	11.40	17.77	29.17	45.03	76.29	110.20	148.20	0.77
			Kv	2.04	4.15	6.54	9.77	15.22	24.99	38.59	65.37	94.43	126.99	---
	60	29	Cv	2.21	3.38	5.36	7.77	11.31	17.10	26.79	40.47	59.09	77.71	0.75
			Kv	1.90	2.90	4.59	6.66	9.69	14.65	22.96	34.68	50.63	66.59	---
6	113	51	Cv	5.23	10.36	17.01	28.69	47.98	77.90	126.35	190.00	255.55	311.60	0.76
			Kv	4.49	8.87	14.57	24.58	41.11	66.75	108.27	162.81	218.98	267.01	---
	73	38	Cv	3.80	7.25	10.55	14.25	22.14	33.25	50.64	75.62	106.40	136.80	0.73
			Kv	3.26	6.21	9.04	12.21	18.97	28.49	43.39	64.80	91.17	117.22	---

Table 16. Angle Type Control Valve—Noise Reduction Trim

Flow up Linear characteristic													
Valve Size	Port Diameter	Maximum Travel	Flow Coefficient	Valve Open-Percent of Total Valve									
NPS	mm	mm		10	20	30	40	50	60	70	80	90	100
1	33	19	Cv	2.06	5.04	8.02	11.21	13.97	15.77	18.53	20.43	21.95	22.90
			Kv	1.77	4.31	6.87	9.61	11.97	13.51	15.87	17.50	18.80	19.62
2	48	19	Cv	4.73	10.45	18.72	26.51	32.78	38.57	43.42	47.60	51.02	53.11
			Kv	4.05	8.95	16.04	22.71	28.08	33.05	37.20	40.78	43.71	45.51
3	73	29	Cv	11.78	28.88	45.89	64.22	79.99	90.44	106.40	116.85	125.40	131.10
			Kv	10.09	24.75	39.32	55.03	68.54	77.50	91.17	100.13	107.46	112.34
4	88	38	Cv	15.87	40.76	64.13	86.64	107.35	126.35	144.40	159.60	172.90	184.30
			Kv	13.59	34.92	54.95	74.24	91.99	108.27	123.74	136.76	148.16	157.93
6	113	51	Cv	27.36	66.88	106.40	149.15	185.25	209.00	247.00	270.75	294.50	304.00
			Kv	23.44	57.31	91.17	127.81	158.74	179.09	211.65	232.01	252.36	260.50



Table18. Globe Control Valve CL125-600—Quick Open Cage

Valve Size	Port Diameter	Maximum Travel	Flow Coefficient	Valve Open-Percent of Total Valve										F <sub>L</sub>
				10	20	30	40	50	60	70	80	90	100	
NPS	mm	mm												
1	33	19	Cv	3.05	5.23	7.77	10.36	12.54	14.25	16.06	17.67	18.91	19.57	0.82
			Kv	2.61	4.48	6.66	8.88	10.75	12.21	13.76	15.14	16.20	16.77	---
1-1/2	48	19	Cv	4.02	7.45	11.21	15.01	19.38	24.04	28.79	32.97	35.34	37.24	0.81
			Kv	3.44	6.38	9.61	12.86	16.61	20.60	24.67	28.25	30.28	31.91	---
2	58	29	Cv	7.48	15.20	23.66	31.73	40.00	49.21	58.90	64.70	67.07	69.26	0.78
			Kv	6.41	13.02	20.27	27.19	34.27	42.17	50.47	55.44	57.47	59.34	---
2-1/2	73	38	Cv	8.87	20.52	33.73	47.03	59.57	70.40	79.42	88.83	96.90	102.60	---
			Kv	7.60	17.58	28.90	40.30	51.04	60.32	68.05	76.11	83.03	87.92	---
3	88	38	Cv	13.78	31.26	49.50	66.88	84.08	99.75	112.10	126.35	134.90	140.60	0.83
			Kv	11.80	26.78	42.41	57.31	72.04	85.48	96.06	108.27	115.60	120.48	---
4	58	38	Cv	7.63	15.52	24.15	32.40	40.84	50.25	60.14	66.06	68.48	70.71	---
	113	51	Cv	22.14	47.79	74.20	99.75	120.65	144.40	171.95	192.85	211.85	224.20	0.84
6	113	51	Cv	22.60	48.79	75.76	101.85	123.19	147.44	175.57	196.91	216.31	228.92	---
	178	51	Cv	43.99	101.65	162.45	216.60	265.05	310.65	348.65	381.90	399.00	411.35	0.85
8	178	51	Cv	44.91	103.79	165.87	221.16	270.63	317.19	355.99	389.94	407.40	420.01	---
	203	76	Cv	86.83	196.65	308.75	418.00	522.50	607.05	675.45	722.00	755.25	803.70	0.87
10	203	76	Cv	88.66	200.79	315.25	426.80	533.50	619.83	689.67	737.20	771.15	820.62	---
	248	102	Cv	50.78	130.52	230.63	370.25	510.34	650.23	770.00	860.14	940.25	1000.00	0.86
12	248	102	Cv	53.32	137.05	242.16	388.76	535.86	682.74	808.50	903.15	987.26	1050.00	---
	278	127	Cv	70.55	180.30	320.14	520.13	710.96	910.41	1060.30	1170.37	1267.20	1358.67	0.82
14	278	127	Cv	74.08	189.32	336.15	546.14	746.51	955.93	1113.32	1228.89	1330.56	1426.60	---
	348	127	Cv	94.00	253.24	586.40	847.30	1124.74	1402.30	1645.30	1870.35	2021.44	2275.00	0.87
16	348	127	Cv	98.70	265.90	615.72	889.67	1180.98	1472.42	1727.57	1963.87	2122.51	2388.75	---
	374	127	Cv	130.00	335.00	580.00	930.00	1280.00	1630.00	1930.00	2150.00	2350.00	2500.00	0.89

Table19. Globe Control Valve CL125-600 Equal Percentage Cage (Flow Down)

Valve Size	Port Diameter	Maximum Travel	Flow Coefficient	Valve Open-Percent of Total Valve										F <sub>L</sub>
				10	20	30	40	50	60	70	80	90	100	
NPS	mm	mm												
1	33	19	Cv	0.74	1.46	2.09	2.75	4.00	5.47	7.44	10.36	13.40	16.34	0.82
			Kv	0.64	1.25	1.79	2.35	3.43	4.69	6.37	8.87	11.48	14.00	---
1-1/2	48	19	Cv	1.44	2.50	3.68	5.14	7.08	10.64	16.53	23.28	29.26	34.01	0.81
			Kv	1.24	2.14	3.15	4.40	6.06	9.12	14.16	19.94	25.07	29.14	---
2	58	29	Cv	1.58	2.78	4.43	6.63	10.26	15.68	24.13	35.44	48.17	56.72	0.78
			Kv	1.35	2.39	3.79	5.68	8.79	13.43	20.68	30.36	41.27	48.60	---
2-1/2	73	38	Cv	3.26	6.77	10.26	14.35	21.28	32.02	46.74	67.55	85.03	94.43	---
			Kv	2.79	5.80	8.79	12.29	18.23	27.43	40.05	57.88	72.86	80.92	---
3	88	38	Cv	4.10	7.15	10.36	16.25	25.84	41.33	62.70	92.15	114.00	129.20	0.83
			Kv	3.52	6.13	8.87	13.92	22.14	35.41	53.73	78.96	97.69	110.71	---
4	58	38	Cv	1.61	2.84	4.52	6.77	10.48	16.01	24.64	36.18	49.18	57.91	---
	113	51	Cv	5.56	11.02	17.39	28.69	47.22	75.72	118.75	162.45	194.75	212.80	0.84
6	113	51	Cv	5.67	11.25	17.75	29.29	48.21	77.31	121.25	165.87	198.85	217.28	---
	178	51	Cv	12.26	24.51	41.14	64.03	98.80	153.90	227.05	300.20	349.60	374.30	0.85
8	178	51	Cv	12.51	25.03	42.00	65.38	100.88	157.14	231.83	306.52	356.96	382.18	---
	203	76	Cv	25.65	55.20	99.75	178.60	291.65	454.10	574.75	660.25	722.95	777.10	0.87
10	203	76	Cv	26.19	56.36	101.85	182.36	297.79	463.66	586.85	674.15	738.17	793.46	---
	248	102	Cv	17.24	32.45	58.67	94.87	170.68	324.47	508.47	678.14	810.49	900.00	0.92
12	248	102	Cv	18.10	34.07	61.60	99.61	179.21	340.69	533.89	712.05	851.01	945.00	---
	278	127	Cv	24.15	45.31	81.67	131.47	236.05	452.10	704.67	914.72	1072.12	1194.00	0.94
14	278	127	Cv	25.36	47.58	85.75	138.04	247.85	474.71	739.90	960.46	1125.73	1253.70	---
	348	127	Cv	31.00	63.14	102.14	150.47	227.60	418.91	789.34	1187.44	1532.07	1900.00	0.92
16	348	127	Cv	32.55	66.30	107.25	157.99	238.98	439.86	828.81	1246.81	1608.67	1995.00	---
	374	127	Cv	55.10	100.70	157.70	260.30	440.80	720.10	1092.50	1548.50	2099.50	2413.00	0.86



Table20. Globe Control Valve CL125-600—Quick Open Cage

Quick Open				Quick Opening Characteristic										
Valve Size	Port Diameter	Maximum Travel	Flow Coefficient	Valve Open-Percent of Total Valve										F <sub>L</sub>
NPS	mm	mm		10	20	30	40	50	60	70	80	90	100	
1	33	19	Cv	4.62	8.92	12.73	16.06	17.96	19.29	20.05	20.71	20.81	21.00	0.81
			Kv	3.96	7.64	10.91	13.76	15.39	16.53	17.18	17.75	17.83	17.99	---
1-1/2	48	19	Cv	7.40	13.68	19.48	25.46	30.40	34.77	37.43	39.24	40.57	41.80	0.79
			Kv	6.34	11.72	16.69	21.82	26.05	29.79	32.07	33.62	34.76	35.82	---
2	58	29	Cv	12.73	25.46	37.91	48.74	59.76	67.07	70.02	71.82	72.96	73.72	0.78
			Kv	10.91	21.82	32.48	41.76	51.20	57.47	60.00	61.54	62.52	63.17	---
2-1/2	73	38	Cv	19.86	37.62	55.86	70.49	80.66	92.15	97.85	100.70	102.60	103.55	---
			Kv	17.01	32.24	47.87	60.40	69.11	78.96	83.85	86.29	87.92	88.73	---
3	88	38	Cv	25.84	49.59	74.01	94.53	117.80	133.00	141.55	146.30	150.10	152.95	0.77
			Kv	22.14	42.49	63.41	81.00	100.94	113.97	121.29	125.36	128.62	131.06	---
4	58	38	Cv	13.00	26.00	38.70	49.76	61.01	68.48	71.49	73.33	74.50	75.27	---
			Kv	11.14	22.28	33.16	42.64	52.28	58.68	61.26	62.84	63.84	64.50	---
4	113	51	Cv	35.82	71.25	118.75	154.85	183.35	209.00	226.10	234.65	238.45	238.45	0.84
			Kv	30.69	61.05	101.76	132.69	157.11	179.09	193.74	201.07	204.33	204.33	---
6	113	51	Cv	36.57	72.75	121.25	158.11	187.21	213.40	230.86	239.59	243.47	243.47	---
			Kv	31.34	62.34	103.90	135.48	160.42	182.86	197.82	205.30	208.63	208.63	---
6	178	51	Cv	69.92	142.50	220.40	290.70	335.35	369.55	395.20	418.95	428.45	437.00	0.85
			Kv	59.91	122.11	188.86	249.10	287.36	316.67	338.65	359.00	367.14	374.46	---
8	178	51	Cv	71.39	145.50	225.04	296.82	342.41	377.33	403.52	427.77	437.47	446.20	---
			Kv	61.18	124.68	192.84	254.34	293.41	323.33	345.78	366.56	374.87	382.35	---
8	203	76	Cv	128.25	276.45	412.30	523.45	607.05	670.70	721.05	766.65	798.95	819.85	0.87
			Kv	109.90	236.89	353.30	448.54	520.18	574.72	617.87	656.94	684.62	702.53	---
10	203	76	Cv	134.66	290.27	432.92	549.62	637.40	704.24	757.10	804.98	838.90	860.84	---
			Kv	115.39	248.73	370.96	470.97	546.19	603.46	648.76	689.79	718.85	737.65	---
10	248	102	Cv	175.14	435.00	733.45	839.21	917.20	972.46	1008.69	1050.33	1080.17	1100.00	0.82
			Kv	150.08	372.75	628.49	719.12	785.95	833.30	864.34	900.03	925.60	942.59	---
12	248	102	Cv	183.90	456.75	770.12	881.17	963.06	1021.08	1059.12	1102.85	1134.18	1155.00	---
			Kv	157.58	391.39	659.92	755.07	825.24	874.96	907.56	945.03	971.88	989.72	---
12	278	127	Cv	235.00	612.34	894.56	1043.77	1225.10	1443.71	1502.12	1541.60	1573.58	1600.00	0.83
			Kv	201.37	524.71	766.55	894.40	1049.79	1237.11	1287.16	1320.99	1348.40	1371.04	---
14	278	127	Cv	246.75	642.96	939.29	1095.96	1286.36	1515.90	1577.23	1618.68	1652.26	1680.00	---
			Kv	211.44	550.95	804.87	939.12	1102.28	1298.97	1351.52	1387.04	1415.82	1439.59	---
14	348	127	Cv	280.00	810.47	1274.95	1637.44	1927.04	1984.50	2031.34	2073.64	2100.00	2120.00	0.81
			Kv	239.93	694.49	1092.50	1403.12	1651.28	1700.51	1740.65	1776.90	1799.49	1816.62	---
16	348	127	Cv	294.00	850.99	1338.70	1719.31	2023.39	2083.73	2132.91	2177.32	2205.00	2226.00	---
			Kv	251.93	729.21	1147.13	1473.28	1733.84	1785.54	1827.68	1865.74	1889.46	1907.46	---
16	374	127	Cv	352.80	1021.19	1606.44	2063.17	2428.07	2500.47	2559.49	2612.79	2646.00	2671.20	0.86
			Kv	302.31	875.06	1376.55	1767.93	2080.61	2142.65	2193.22	2238.89	2267.35	2288.95	---

Table21. Globe Control Valve CL125-600—Noise Reduction, Anti-cavitation Trim

Flow up					Linear characteristic									
Valve Size	Port Diameter	Maximum Travel	Flow Coefficient	Valve Open-Percent of Total Valve										
NPS	mm	mm		10	20	30	40	50	60	70	80	90	100	
1	33	19	Cv	2.44	4.18	6.22	8.29	10.03	11.40	12.85	14.14	15.13	15.66	
			Kv	2.09	3.59	5.33	7.10	8.60	9.77	11.01	12.11	12.96	13.42	
1-1/2	48	19	Cv	3.38	6.27	9.44	12.64	16.32	20.24	24.24	27.76	29.76	31.36	
			Kv	2.90	5.37	8.09	10.83	13.98	17.34	20.77	23.79	25.50	26.87	
2	58	29	Cv	6.30	12.80	19.92	26.72	33.68	41.44	49.60	54.48	56.48	58.32	
			Kv	5.40	10.97	17.07	22.90	28.86	35.51	42.50	46.68	48.40	49.97	
2-1/2	73	38	Cv	7.47	17.28	28.40	39.60	50.16	59.28	66.88	74.80	81.60	86.40	
			Kv	6.40	14.81	24.34	33.93	42.98	50.80	57.31	64.10	69.92	74.04	
3	88	38	Cv	11.60	26.32	41.68	56.32	70.80	84.00	94.40	106.40	113.60	118.40	
			Kv	9.94	22.55	35.72	48.26	60.67	71.98	80.89	91.17	97.34	101.46	
4	58	38	Cv	6.61	13.44	20.92	28.06	35.36	43.51	52.08	57.20	59.30	61.24	
			Kv	5.66	11.52	17.92	24.04	30.30	37.29	44.63	49.02	50.82	52.47	
4	113	51	Cv	18.64	40.24	62.48	84.00	101.60	121.60	144.80	162.40	178.40	188.80	
			Kv	15.97	34.48	53.54	71.98	87.06	104.20	124.08	139.16	152.87	161.78	
6	113	51	Cv	19.57	42.25	65.60	88.20	106.68	127.68	152.04	170.52	187.32	198.24	
			Kv	16.77	36.21	56.22	75.58	91.41	109.41	130.28	146.12	160.51	169.87	
6	178	51	Cv	37.04	85.60	136.80	182.40	223.20	261.60	293.60	321.60	336.00	346.40	
			Kv	31.74	73.35	117.22	156.30	191.26	224.16	251.59	275.58	287.92	296.83	
8	178	51	Cv	38.89	89.88	143.64	191.52	234.36	274.68	308.28	337.68	352.80	363.72	
			Kv	33.33	77.02	123.08	164.11	200.82	235.37	264.16	289.36	302.31	311.67	
8	203	76	Cv	73.12	165.60	260.00	352.00	440.00	511.20	568.80	608.00	636.00	676.80	
			Kv	62.66	141.90	222.79	301.63	377.04	438.05	487.40	520.99	544.99	579.95	
10	203	76	Cv	76.78	173.88	273.00	369.60	462.00	536.76	597.24	638.40	667.80	710.64	
			Kv	65.79	149.00	233.93	316.71	395.89	459.95	511.77	547.04	572.24	608.95	
10	248	102	Cv	40.62	104.42	184.50	296.20	408.27	520.18	616.00	688.11	752.20	800.00	
			Kv	34.81	89.47	158.10	253.81	349.85	445.74	527.85	589.64	644.56	685.52	
12	248	102	Cv	42.66	109.64	193.73	311.01	428.69	546.19	646.80	722.52	789.81	840.00	
			Kv	36.55	93.95	166.01	266.50	367.34	468.03	554.24	619.12	676.79	719.79	
12	278	127	Cv	56.44	144.24	256.11	416.10	568.77	728.33	848.24	936.30	1013.76	1086.94	
			Kv	48.36	123.60	219.46	356.56	487.38	624.10	726.86	802.31	868.69	931.39	
14	278	127	Cv	59.26	151.45	268.92	436.91	597.21	764.74	890.65	983.11	1064.45	1141.28	
			Kv	50.78	129.78	230.43	374.39	511.74	655.31	763.20	842.43	912.12	977.96	
14	348	127	Cv	75.20	202.59	469.12	677.84	899.79	1121.84	1316.24	1496.28	1617.15	1820.00	
			Kv	64.44	173.60	401.99	580.84	771.03	961.30	1127.88	1282.16	1385.73	1559.55	
16	348	127	Cv	78.96	212.72	492.58	711.73	944.78	1177.93	1382.05	1571.09	1698.01	1911.00	
			Kv	67.66	182.28	422.09	609.88	809.58	1009.37	1184.28	1346.27	1455.02	1637.53	
16	374	127	Cv	110.50	284.75	493.00	790.50	1088.00	1385.50	1640.50	1827.50	1997.50	2125.00	
			Kv	94.69	244.00	422.45	677.38	932.31	1187.23	1405.74	1565.98	1711.65	1820.91	



Table 22. Globe Control Valve CL125-600—Anti-aircraft Trim

Flow up				Linear characteristic									
Valve Size	Port Diameter	Maximum Travel	Flow Coefficient	Valve Open-Percent of Total Valve									
NPS	mm	mm		10	20	30	40	50	60	70	80	90	100
1	33	19	Cv	2.29	3.92	5.83	7.77	9.41	10.69	12.05	13.25	14.18	14.68
			Kv	1.96	3.36	4.99	6.66	8.06	9.16	10.32	11.36	12.15	12.58
1-1/2	48	19	Cv	3.17	5.88	8.85	11.85	15.30	18.98	22.73	26.03	27.90	29.40
			Kv	2.72	5.04	7.58	10.15	13.11	16.26	19.47	22.30	23.91	25.19
2	58	29	Cv	5.90	12.00	18.68	25.05	31.58	38.85	46.50	51.08	52.95	54.68
			Kv	5.06	10.28	16.00	21.47	27.06	33.29	39.85	43.77	45.37	46.85
2-1/2	73	38	Cv	7.01	16.20	26.63	37.13	47.03	55.58	62.70	70.13	76.50	81.00
			Kv	6.00	13.88	22.81	31.81	40.30	47.62	53.73	60.09	65.55	69.41
3	88	38	Cv	10.88	24.68	39.08	52.80	66.38	78.75	88.50	99.75	106.50	111.00
			Kv	9.32	21.14	33.48	45.24	56.88	67.48	75.84	85.48	91.26	95.12
4	58	38	Cv	6.20	12.60	19.61	26.30	33.15	40.79	48.83	53.63	55.60	57.41
			Kv	5.31	10.80	16.80	22.54	28.41	34.96	41.84	45.95	47.64	49.19
	113	51	Cv	17.48	37.73	58.58	78.75	95.25	114.00	135.75	152.25	167.25	177.00
			Kv	14.97	32.33	50.19	67.48	81.62	97.69	116.32	130.46	143.32	151.67
6	113	51	Cv	18.35	39.61	61.50	82.69	100.01	119.70	142.54	159.86	175.61	185.85
			Kv	15.72	33.94	52.70	70.85	85.70	102.57	122.14	136.99	150.48	159.25
	178	51	Cv	34.73	80.25	128.25	171.00	209.25	245.25	275.25	301.50	315.00	324.75
			Kv	29.76	68.77	109.90	146.53	179.31	210.15	235.86	258.35	269.92	278.28
8	178	51	Cv	36.46	84.26	134.66	179.55	219.71	257.51	289.01	316.58	330.75	340.99
			Kv	31.24	72.20	115.39	153.86	188.27	220.66	247.65	271.27	283.42	292.19
	203	76	Cv	68.55	155.25	243.75	330.00	412.50	479.25	533.25	570.00	596.25	634.50
			Kv	58.74	133.03	208.87	282.78	353.47	410.67	456.94	488.43	510.93	543.70
10	203	76	Cv	71.98	163.01	255.94	346.50	433.13	503.21	559.91	598.50	626.06	666.23
			Kv	61.68	139.69	219.31	296.92	371.14	431.20	479.79	512.85	536.47	570.89
	248	102	Cv	38.09	97.89	172.97	277.69	382.76	487.67	577.50	645.11	705.19	750.00
			Kv	32.63	83.88	148.22	237.95	327.98	417.89	494.86	552.79	604.27	642.67
12	248	102	Cv	39.99	102.78	181.62	291.57	401.89	512.06	606.38	677.36	740.45	787.50
			Kv	34.27	88.08	155.63	249.85	344.38	438.78	519.60	580.43	634.49	674.81
	278	127	Cv	52.91	135.23	240.11	390.10	533.22	682.81	795.23	877.78	950.40	1019.00
			Kv	45.34	115.87	205.75	334.27	456.92	585.10	681.43	752.17	814.40	873.18
14	278	127	Cv	55.56	141.99	252.11	409.60	559.88	716.95	834.99	921.67	997.92	1069.95
			Kv	47.61	121.67	216.03	350.99	479.76	614.35	715.50	789.77	855.12	916.84
	348	127	Cv	70.50	189.93	439.80	635.48	843.56	1051.73	1233.98	1402.76	1516.08	1706.25
			Kv	60.41	162.75	376.86	544.54	722.84	901.22	1057.39	1202.02	1299.13	1462.08
16	348	127	Cv	74.03	199.43	461.79	667.25	885.73	1104.31	1295.67	1472.90	1591.88	1791.56
			Kv	63.43	170.89	395.71	571.76	758.98	946.28	1110.26	1262.13	1364.08	1535.19
	374	127	Cv	100.10	257.95	446.60	716.10	985.60	1255.10	1486.10	1655.50	1809.50	1925.00
			Kv	85.78	221.04	382.69	613.62	844.56	1075.49	1273.44	1418.59	1550.56	1649.53

Pneumatic Actuator

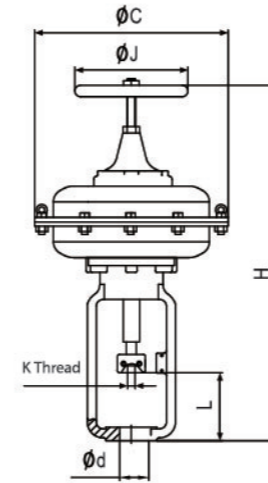

Figure 8. DL Series Actuator

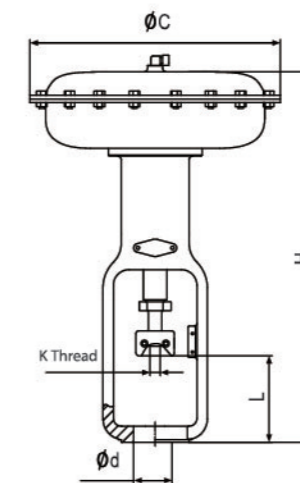

Figure 9. 857/867 Series Actuator

DL Series Actuator Technical Data Sheet

Model	Max Travel (mm)	Nominal Effective Diaphragm Area (cm <sup>2</sup> )	Spring Range (Kpa)	Material Temperature Capabilities (°C)	L (mm)	Without Hand-wheel H(mm)	Top-mounted Hand-wheel		Φd (mm)	K Thread	ΦC (mm)	Weight (kg)	
							H(mm)	ΦJ(mm)				Without Hand-wheel	Top-mounted Hand-wheel
DL A B 23	25	350	20~100	Ethylene-propylene rubber clip nylon -30~120 °C	115	371	525	200	54	3/8"-24UNF	285	15	20
DL A B 34	40	560			177	470	675	200	71	1/2"-20UNF	360	24	31
DL A B 45	60	900			236	600	840	300	90	3/4"-16UNF	470	42	49

857/867 Actuator Technical Data Sheet

Model	Max Travel (mm)	Nominal Effective Diaphragm Area (cm <sup>2</sup> )	Spring Range (Kpa)	Material Temperature Capabilities (°C)	L(mm)		H (mm) Without Hand-wheel		H (mm) Top-mounted Hand-wheel		Φd (mm)	K Thread	ΦC (mm)	Weight (kg)	
					857	867	857	867	857	867				857	867
30	19	297	20~100	Nitrile synthetic rubber -40~+82	212.7	193.6	440	478	561	597	54	3/8"-24UNF	289	16	15
34	29	445			220.7	225.5	498	573	662	694	54	3/8"-24UNF	333	22	22
40	38	445			272.2	248.1	548	594	712	731	71	1/2"-20UNF	333	23	23
45	51	677	40~200	Silane synthetic rubber -54~+149	290.5	310.1	659	768	861	927	71	1/2"-20UNF	406	37	41
46	51	1006			290.5	310.1	656	748	858	907	71	1/2"-20UNF	473	49	55
50	51	677	200	Fluorous rubber -18~+149	354	325.4	722	784	924	943	90	3/4"-16UNF	406	42	43
60	51	1006			354	325.4	722	784	924	943	90	3/4"-16UNF	473	53	55
70	76	1419			406	375	840	933	1153	1219	90	3/4"-16UNF	536	107	115



## Technical specifications

### Configuration

- Globe type: Single-seat, Globe type control valve cage guiding balanced valve plug (Figure 1)
- Angle type: Angle type control valve, use in facilitate the tube or request body emission fluid situation

### Valve Size(See Table 4)

### End Connection Type

Steel & Stainless Steel Valve

- Flange Connection: 1~14", ANSI Class 150, 300, 600 RF or RTJ according to ASME B16.5
- Butt Weld Connection: 1~14", Pipe wall thickness sch.40 or sch.80, confirms to ASME B16.25

### Max inlet pressure and temperature

List as follows, unless limited by the maximum pressure drop or material temperature range.

### Steel & Stainless Steel Valve

- Flange Connection: ANSI Class150, 300 and 600 according to ASME B16.34.
- Weld Connection: Confirms to 600# stipulation of ASME B16.34 standard.

### Structure & Material

Plug & Metal-seat Parts (See Table 5)  
All Other Parts (See Table 6)

### Sealing Class and Temperature Range (See Table 3)

### Flow Characteristic

- Standard Cage: fast Opening, linear, equal percentage
- Noise reduction, anti- cavitation & aircraft type trim: linear

### Flow Direction

- Globe or Angle Type: Standard Cage-Flow down
- Noise reduction, anti- cavitation & aircraft type trim-Flow up

### Flow Coefficient

Refer to tables which titled "coefficient" in this product brochure.

### Size and Plug Travel (See Coefficient Table 14-Table 25)

### Stem Diameter

- Globe Type(See Table 11)
- Angle Type(See Table 13)

### Packing System

PTFE V-Ring & Graphite System (See Figure 3)

### Approximate Weights(kg)

1"	16
1-1/2"	21
2"	43
2-1/2"	47
3"	61
4"	82
6"	164
8"	441
10"	536
12"	714
14"	1045
16"	1377

### Other Optional

- Body/Bonnet sealing connection type
- Bonnet can be extended according to the requirements of orders, suitable for deep freezing and high temperature applications.
- Applies to class V shutoff sealing valve trim